

Modelling the Semantic Change Dynamics using Diachronic Word Embedding

Mohamed Boukhaled, Benjamin Fagard, Thierry Poibeau

► **To cite this version:**

Mohamed Boukhaled, Benjamin Fagard, Thierry Poibeau. Modelling the Semantic Change Dynamics using Diachronic Word Embedding. 11th International Conference on Agents and Artificial Intelligence (NLPinAI Special Session), Feb 2019, Prague, Czech Republic. hal-02048377

HAL Id: hal-02048377

<https://hal.archives-ouvertes.fr/hal-02048377>

Submitted on 25 Feb 2019

HAL is a multi-disciplinary open access archive for the deposit and dissemination of scientific research documents, whether they are published or not. The documents may come from teaching and research institutions in France or abroad, or from public or private research centers.

L'archive ouverte pluridisciplinaire **HAL**, est destinée au dépôt et à la diffusion de documents scientifiques de niveau recherche, publiés ou non, émanant des établissements d'enseignement et de recherche français ou étrangers, des laboratoires publics ou privés.

Modelling the Semantic Change Dynamics using Diachronic Word Embedding

Mohamed Amine Boukhaled¹, Benjamin Fagard¹ and Thierry Poibeau¹

¹*Laboratoire Langues, Textes, Traitements informatique, Cognition
(LATTICE, CNRS, ENS & Université Paris 3; PSL & USPC), Paris, France
{amine.boukhaled, benjamin.fagard, thierry.poibeau}@ens.fr*

Keywords: Semantic Change, Diachronic Word Embedding, Recurrent Neural Networks, Distributional Semantics, Computational Modelling.

Abstract: In this contribution, we propose a computational model to predict the semantic evolution of words over time. Though semantic change is very complex and not well suited to analytical manipulation, we believe that computational modelling is a crucial tool to study such phenomenon. Our aim is to capture the systemic change of word's meanings in an empirical model that can also predict this type of change, making it falsifiable. The model that we propose is based on the long short-term memory units architecture of recurrent neural networks trained on diachronic word embeddings. In order to illustrate the significance of this kind of empirical model, we then conducted an experimental evaluation using the Google Books N-Gram corpus. The results show that the model is effective in capturing the semantic change and can achieve a high degree of accuracy on predicting words' distributional semantics.

1 INTRODUCTION

The availability of very large textual corpora spanning several centuries has recently made it possible to observe empirically the evolution of language over time. This observation can be targeted toward a few isolated words or a specific linguistic phenomenon, but it can also be interesting to combine these specific studies with the search for more general laws of language evolution. In this contribution, we propose a computational model that aims to predict the semantic evolution of words over time. Computational modelling of language change is a relatively new discipline, which includes early works that aimed at characterizing the evolution through statistical and mathematical modelling (Bailey 1973; Kroch 1989) and more recent and advanced works involving artificial intelligence, robotics and large-scale computer simulations (Steels, 2011).

Semantic change, on which we shall focus in this paper, includes all changes affecting the meaning of lexical items over time. For example, the word *awful* has drastically changed in meaning, moving away from a rather positive connotation, as an equivalent of *impressive* or *majestic*, at the

beginning of the nineteenth century, and toward a negative one, as an equivalent of *disgusting* and *messy* nowadays (Oxford Dictionary 1989). It has been established that there are some systemic regularities that direct the semantic shifts of words meanings. Not all words exhibit the same degree and speed of semantic change. Some words (or word categories) might be more resistant than others to the phenomenon of semantic change, as proposed by (Dubossarsky *et al.*, 2015). Various hypotheses have been proposed in the literature to explain such regularities in semantic change from a linguistic point of view (Traugott and Dasher, 2001).

In this work, we address the question of semantic change from a computational point of view. Our aim is to capture the systemic change of a word's meanings in an empirical model that can also predict such changes, making it falsifiable. The proposed model makes use of two techniques:

1. *Diachronic word embeddings* to represent the meanings of words over time as the data component of the model
2. *A recurrent neural network* to learn and predict the temporal evolution patterns of these data

The idea is to train a Long Short Term Memory units (LSTMs) recurrent neural network (RNN) on word embeddings corresponding to given time-periods (measured in decades) and try to predict the word embeddings of the following decade. We then evaluate the model using a large scale diachronic corpus, namely the English Google Books N-Gram corpus.

The rest of the paper is organized as follows: Section 2 presents a brief review of related works concerned with the computational study of semantic change and regularities. Section 3 discusses the vector word representation using diachronic word embedding and describes our approach based on LSTMs recurrent neural networks for predicting the semantic change. Finally, the proposed model is experimentally evaluated and discussed on the Google Books N-Gram corpus in Section 4.

2 RELATED WORKS ON COMPUTATIONAL ANALYSIS OF SEMANTIC CHANGE

One of the main challenges facing researchers studying the phenomenon of semantic change is its formidable complexity. It seems impossible to grasp all details and factors involved in such change, its abstract nature making it analytically intractable. However, computational models have no difficulties in handling complexity, and can therefore be used as means to make the study of semantic changes more accessible.

The computational study of text temporality in general, and semantic change in particular, has become an active research topic, especially with the emergence of new and more effective methods of numerical word representations. The interest of taking into account the temporal dimension and the diachronic nature of meaning change as a research direction has been effectively demonstrated in several studies. It makes it possible to analyse trajectories of meaning change for an entire lexicon (Kim *et al.*, 2014), to model temporal word analogy or relatedness (Rosin, Radinsky and Adar, 2017) (Szymanski, 2017), to capture the dynamics of semantic relations (Kutuzov, Velldal and Øvrelid, 2017), and even to spell out specific laws of semantic change, among which:

- *The Law of Conformity*, according to which frequency is negatively correlated with semantic change (Hamilton, Leskovec and Jurafsky, 2016b).

- *The Law of Innovation*, according to which polysemy is positively correlated with semantic change (Hamilton, Leskovec and Jurafsky, 2016b).

- *The Law of Prototypicality*, according to which prototypicality is negatively correlated with semantic change (Dubossarsky *et al.*, 2015).

However, these works, despite the fact that they are highly useful for our purposes, are mostly based on descriptive formalisms and they do not attempt to explore predictive approaches (Bollack, 1903).

In this work, our aim is to model the semantic change based on a predictive approach. These predictions can then be examined through empirical observation and experimentation.

3 PROPOSED METHODOLOGY

In this attempt to capture semantic change, our goal is to define a model capable of learning how the meanings of words have changed over time, and then use this model to predict how these meanings may evolve. This can then be checked against the actual meaning change which can be assessed with the same corpus. We propose a model that consists of two steps. The first step is to represent the evolution of word meanings over time using diachronic word embedding. The second consists in learning the temporal pattern behind this evolution using a recurrent neural network. The next two subsections describe more thoroughly these two steps.

3.1 Modelling Semantic Change with Diachronic Word Embedding

To represent computationally the meaning of words over time-periods, it is necessary first to extract the embedded projections of these words in a continuous vector space according to their contextual relationships (Turney and Pantel, 2010). Various methods can be used to obtain such vectors, such as Latent Semantic Analysis (Deerwester *et al.*, 1990) and Latent Dirichlet Allocation (Blei, Ng and Jordan, 2003). However, more recent and advanced techniques such as word2vec (Mikolov *et al.*, 2013) and GloVe (Pennington, Socher and Manning, 2014), known commonly as word embedding techniques, seem capable of better representing the semantic properties and the contextual meaning of words compared to traditional methods. Indeed, word embedding techniques have established

themselves as an important step in the processing pipeline of natural languages.

The word2vec algorithm is one of the most frequently used techniques to construct word embeddings with a huge impact in the field. It consists in training a simple neural network with a single hidden layer to perform a certain task (see Figure 1). Training is achieved through stochastic gradient descent and back-propagation.

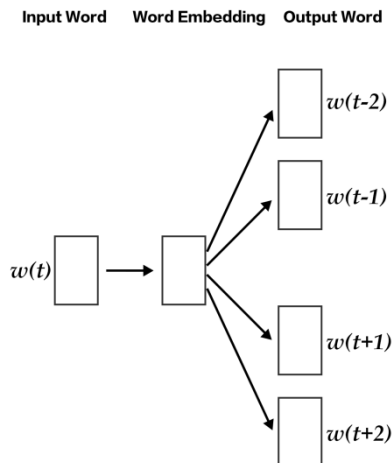

Figure 1: Architecture of the Skip-gram Model (Mikolov *et al.*, 2013)

In the case of the skip-gram with negative sampling (SGNS) variant of the algorithm (Mikolov *et al.*, 2013), the learning task is as follows: Given a specific word in the middle of a sentence, the model uses this current word to predict the surrounding window of context words. The words are in fact projected from a discrete space of V dimensions (where V is the vocabulary size) onto a lower dimensional vector space using the neural network.

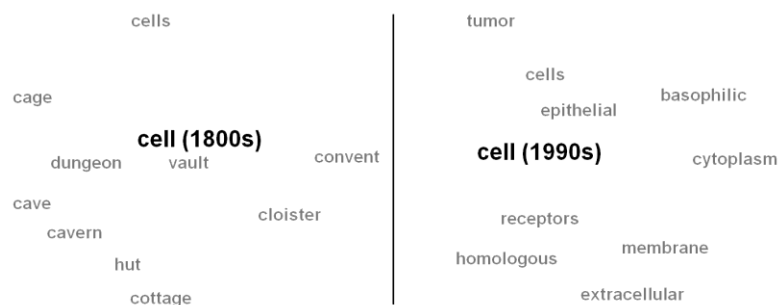

Figure 2: Two-dimensional visualization of the semantic change in the English word *cell* using diachronic word embedding. In the early 19th century *cell* referred to *cage* or *dungeon*, in the late 20th century its meaning shifted toward a scientific usage.

The

goal is not to use the network afterward. Instead, it is just to learn the weights of the hidden layer. These weights constitute actually the word embedding vectors. Despite its simplicity, the word2vec algorithm, given an appropriate amount of training text, is highly effective in capturing the contextual semantics of words.

Such word embedding techniques can be extended to work in a diachronic perspective. The method consists first in training and constructing embeddings for each time-period, then in aligning them temporally, so as to finally use them as means to track semantic change over time (see Figure 2).

In our case, the pre-trained diachronic word embeddings were constructed on the basis of time-periods measured by decades from 1800 to 1990 (Hamilton, Leskovec and Jurafsky, 2016b). The training text used to produce these word embeddings is derived from the Google Books N-gram datasets (Lin *et al.*, 2012) which contain large amounts of historical texts in many languages (N-Grams from approximately 8 million books, roughly 6% of all books published at that time). Each word in the corpus appearing from 1800 to 1999 is represented by a set of twenty continuous 300-*th* dimensional vectors; one vector for each decade.

3.2 Predicting Semantic Change with Recurrent Neural Networks

As we are interested in predicting a continuous vector of d dimensions representing a word's contextual meaning in a given decade, this task is considered to be a regression problem (by opposition to a classification problem, where the task is to predict a discrete class).

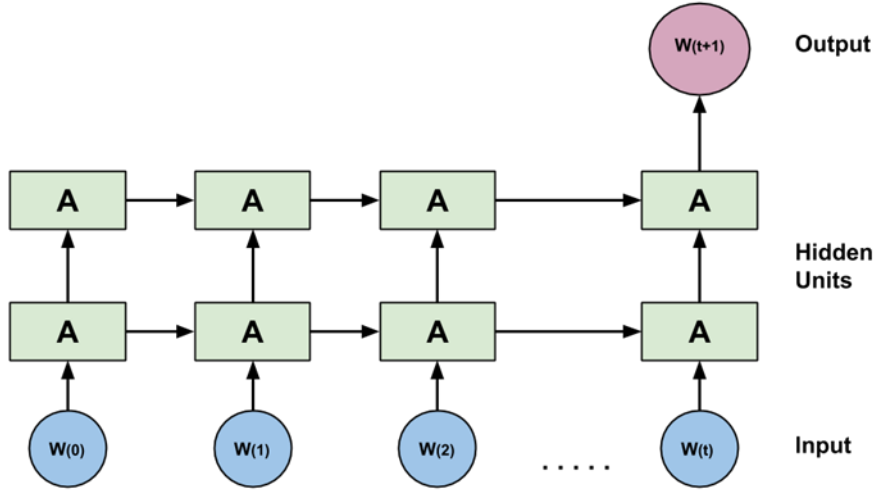

Figure 3: The many-to-one LSTMs architecture used in our work to predict word embedding vectors. For each word in the vocabulary, the network is trained on diachronic word embedding vectors of time-periods $(1, \dots, t)$ as input and tries to predict the embedding vector for time $t + 1$ as output

Many algorithms have been proposed in the literature to deal with this kind of temporal pattern recognition problem, such as Hidden Markov Models (Bengio, 1999) and Conditional Random Fields (Lafferty, McCallum and Pereira, 2001). In this work, we propose to use a recurrent neural network with a many-to-one LSTMs architecture to address this problem.

RNNs are a powerful class of artificial neural networks designed to recognise dynamic temporal behaviour in sequences of data such as textual data (Medsker and Jain, 2001). RNNs are distinguished from feed-forward networks by the feedback loop connected to their past states. In this feedback loop, the hidden state h_t at time step t is a function F of the input at the same time step x_t modified by a weight matrix W , added to the hidden state of the previous time step h_{t-1} multiplied by its own transition matrix U as in equation (1):

$$h_t = F(Wx_t + Uh_{t-1}) \quad (1)$$

More specifically, we used a LSTMs architecture (Hochreiter and Schmidhuber, 1997) (see Figure 3) which is a variety of RNNs designed to deal effectively with the problem of vanishing gradient that RNNs suffer from while training (Pascanu, Mikolov and Bengio, 2013).

3.3 Problem Formulation

Let us consider a vocabulary V_n consisting in the top- n most frequent words of the corpus and $W(t) \in R^{d \times n}$ to be the matrix of word embeddings at time step t .

The LSTMs network is trained on word embeddings over time-period $(1, \dots, t)$ as input and asked to predict word embeddings $\widehat{W}(t+1)$ of time $t+1$ as output. The predicted embedding $\widehat{W}(t+1)$ is then compared to the ground truth word embedding $W(t+1)$ in order to assess the prediction accuracy. Predicting a continuous 300-*th* dimensional vector representing a word's contextual meaning is thus, as indicated above, formulated as a regression problem. Traditionally, researchers use mean-squared-error or mean absolute-error cost functions to assess the performance of regression algorithms. However, in our case, such cost functions would not be adapted, as they provide us with an overview (i.e., numerical value) of how the model is performing but little detail on its prediction accuracy. To have a more precise assessment of the prediction accuracy, we need to be able to say whether the prediction, for each word taken individually, is correct or not. Overall prediction accuracy is then computed. To do so, we proceed as follows:

Given the vocabulary V_n constituted from the top- n most frequent words and the matrix $W(t)$ of word embeddings at decade t , let us consider a word $x_i \in V_n$ and $\widehat{w}_i(t+1)$ its predicted word-embedding at decade $t+1$. Though it is impossible to predict exactly the same ground truth vector $w_i(t+1)$ for this decade, as we are working on a continuous 300-*th* dimensional space, one can assess the accuracy of the predicted vector $\widehat{w}_i(t+1)$ by extracting the words that are closest semantically based on cosine-similarity measure. If the word x_i is actually the nearest semantic neighbour to the predicted vector $\widehat{w}_i(t+1)$ then it is considered to be a correct prediction. Otherwise, it is considered to be a false prediction.

4 EXPERIMENTAL EVALUATION

In our experiment, we used word embeddings of all decades from 1800 to 1990 as input for the network, and we trained it to predict the embeddings of the 1990-1999 decade as output. We then conducted two types of evaluations. The first one consisted in reconstructing the overall large-scale evolution of the prediction accuracy on most frequent words from the corpus. The second consisted in evaluating the prediction accuracy for a handful of word forms that have known considerable semantic shifts in the past two centuries. The next two subsections describe the experimental protocol and results for both evaluations.

4.1 Overall Evaluation

In this first part of the evaluation, we experimented with different vocabulary sizes (top-1,000, 5,000, 10,000 and 20,000 words respectively, consisting of the most frequent words as computed from their average frequency over the entire historical time-periods). The experimental settings can help us evaluate the effect of a word’s frequency on the degree of semantic change, and hence on prediction accuracy. For each experiment, and in order to get a reasonable estimate of the expected prediction performance, we used a 10-fold cross-validation method. Each time, we used 90% of the words for training the model, and the remaining 10% for testing its prediction accuracy. The training and testing process was repeated 10 times. The overall

prediction accuracy is taken as the average performance over these 10 runs.

The results of measuring the prediction accuracy in our experimental evaluation are summarised in Table 1.

Table 1: Results of prediction accuracy measured for different vocabulary sizes.

Vocabulary Size	Acc.
1,000	91.7%
5,000	86.1%
10,000	71.4%
20,000	52.2%

The results show that the model can be highly effective in capturing semantic change and can achieve a high accuracy when predicting words’ distributional semantics. For example, the model was able to achieve 71% accuracy trained and tested exclusively on embeddings coming from the 10,000 most frequent words of the corpus. The results also show a better performance when using a smaller vocabulary size, containing only the most frequent words. This is due to the fact that frequent words are repeated a sufficient number of times for the embedding algorithm to represent them accurately, and therefore to have a better distinction of the semantic change pattern which those embeddings may contain, which in turn can lead the RNN model to better capture this semantic change pattern and yield a more accurate prediction. Indeed, having a large corpus is essential to enable the models to learn a better word representation. These results are also in line with previous works claiming that frequency plays an important role in the semantic change process. For instance, Hamilton et al. (2016b) have shown that frequent words tend to be more resistant to semantic change (statistical Law of Conformity).

4.2 Case Studies

We further examined the prediction accuracy on a handful of words. We automatically extracted, as explained below, from the Google Books N-Gram Corpus the top-100 words that have known considerable semantic shifts in the past two centuries. We noticed that these words correspond mostly to cases that have undergone some important

Table 2: Neighbouring words according to cosine similarity for sample words that have known considerable semantic shifts in the past two centuries

Word	Neighbours in 1800s	Neighbours in 1990s
<i>mail</i>	<i>waistcoat, boots, shirt, gloves, breeches, velvet, pistols, shoe, helmet, spurs</i>	<i>mailing, email, send, internet, telephone, sending, fax, messages, mails, postage</i>
<i>circuit</i>	<i>habitable, district, lanes, range, area, outer, globe, traverse</i>	<i>circuits, appeals, amplifier, voltage, transistor, capacitor, appellate, court, resistor, district</i>
<i>signal</i>	<i>commodore, hoisted, victory, tack, admiral, commemoration, victories, chace, flag, announce</i>	<i>signals, modulated, amplitude, input, noise, modulation, transmitter, analog, waveform, transduction</i>
<i>array</i>	<i>banners, spears, shields, ensigns, ranged, pikes, trumpets, banner, standards</i>	<i>arrays, variety, range, integers, integer, byte, wide, pointer, formats, pointers</i>

cultural shifts, which makes them a harder challenge for the prediction model compared to datasets used earlier in the overall evaluation. Table 2 presents sample words that gained new meanings due to their evolution towards uses in scientific and technological contexts.

From a technical point of view, one can computationally examine the degree of semantic change using two different measures.

The first one, known as the global measure, simply consists in computing the cosine distance between a given word’s vectors from two consecutive decades t and $t + 1$. The bigger the distance, the higher the semantic change (Kim *et al.*, 2014).

The second measure, which we chose to use in our work, is known as the local neighbourhood measure, recommended by Hamilton, Leskovec and Jurafsky (2016a). It consists of evaluating the semantic change of a word based on how much its corresponding semantic neighbours have changed between two consecutive decades.

To do so, we first extract for each word x_i , with its corresponding embedding vector w_i , the set of k most nearest neighbours, denoted by $N_k(x_i)$, according to cosine-similarity for both consecutive decades t and $t + 1$. Then, to measure the change which took place between these two decades, we compute a second-order similarity vector for $x_i^{(t)}$ from these neighbour sets. This second-order vector, denoted by $s_i^{(t)}$, contains the cosine similarity of w_i and the vectors of all x_i ’s nearest semantic neighbours in the time-periods t and $t + 1$, with entries defined as:

$$S^{(t)}(j) = \text{cosine} - \text{sim}(w_i^{(t)}, w_j^{(t)}) \quad (2)$$

$$\forall x_j \in N_k(x_i^{(t)}) \cup N_k(x_i^{(t+1)})$$

An analogous vector for $x_i^{(t+1)}$ is similarly computed as well.

Finally, we compute the local neighbourhood distance that measures the extent to which x_i ’s similarity with its nearest neighbours has changed as:

$$d(x_i^{(t)}, x_i^{(t+1)}) = \text{cosine} - \text{dist}(s_i^{(t)}, s_i^{(t+1)}) \quad (3)$$

Hamilton, Leskovec and Jurafsky (2016a) have found that the local neighbourhood measure is more effective in capturing specific cultural and semantic shifts than the global measure, while being less sensitive to other types of change such as grammaticalization.

The model was able to correctly predict the semantic evolution of 41% of the studied cases, including words that have known an important and attested semantic change in the last two centuries such as the word *cell*. Moreover, a large portion of the false predictions corresponds to borderline cases for which the model has a tendency to predict vectors that are closer to much more frequent words, occurring in the same semantic context in the corpus, such as predicting a vector closer to the (emerging but more frequent) word *optimistic* for the (declining) word *sanguine*. The word *sanguine* comes from Old French *sanguin* (itself from Latin *sanguineus*, on *sanguis* ‘blood’). It originally means ‘blood-red’ (14th c., Merriam-Webster’s), and by

extension ‘hopeful, optimistic’ (15th c., *ibid.*). In our corpus examples from the early 18th c., it is already used with the meaning ‘optimistic’, as in “My lords, I am sanguine enough to believe that this country has in a great measure got over its difficulties” (*Speech of the Earl of Liverpool*, 1820: 31) and “she is sanguine enough to expect that her various Novelties will meet the approbation of all Ladies of taste” (*La belle assemblee*, vol. XV, April 1st, 1817). But Figure 4 shows that its frequency in the 19th and 20th c. has dropped steadily, while *optimistic* has seen its frequency rise sharply. Thus, the pair *sanguine* / *optimistic* seems to be a good example of lexical replacement, which explains our model’s prediction.

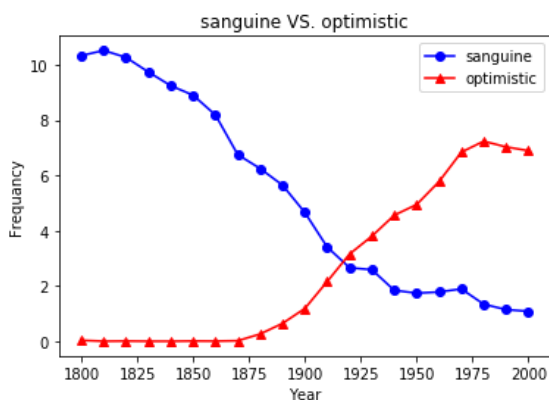

Figure 4: Frequency profiles of *sanguine* and *optimistic* in Google Books N-Gram Corpus measured in millions.

Thus, among other benefits for historical linguists, our method makes it possible to identify the semantic replacement of one word by another in a specific context.

4.3 Discussion

Despite being effective in predicting the semantic evolution of words, some difficulties remain regarding our method. For instance, our model works best for the most frequent words, i.e., according to the Law of Conformity, those with the least semantic evolution. One could thus wonder whether the words for which the model correctly predicts the semantic are not simply those which display little or no semantic change. The examples given in section 4.2 show that this is at least not always the case, but a more systematic investigation of individual cases is in order to get a clear picture.

Another way to answer this question would be to explore more finely the effect that both polysemy and word frequency may have on our results, especially on the word representation part of our model. These two factors have been shown to play an important role in the semantic change, and their effects need to be studied and formalized more explicitly. Exploring more advanced and semantic-oriented word embedding techniques, referred to as sense embeddings, such as SENSEMBED (Iacobacci, Pilehvar and Navigli, 2015), could help make the model less sensitive to those factors.

5 CONCLUSIONS

In conclusion, we describe in this paper a method that accurately models the evolution of language and that can to some extent predict future evolution, based on past observations. Although our experiment is still in its preliminary stages, we believe it can provide linguists with a refreshing look on linguistic evolution. Our method makes it possible to observe large-scale evolution in general and semantic change in particular. It thus nicely complements existing methods and reinforces a falsifiability approach to linguistics. Based on the current study, we have identified several future research directions from a technical point of view. The RNN model that we propose to use is rather standard and simplistic compared to the complexity of semantic change. We therefore intend to explore deeper networks and to put more time and effort in the fine tuning process of its hyper-parameters.

ACKNOWLEDGEMENTS

This work is supported by the project 2016-147 ANR OPLADYN TAP-DD2016. Our Thanks go to the anonymous reviewers for their constructive comments.

REFERENCES

- Bailey, C.-J. N. (1973) ‘Variation and linguistic theory.’ ERIC.
- Bengio, Y. (1999) ‘Markovian models for sequential data’, *Neural computing surveys*, 2(199), pp. 129–162.
- Blei, D. M., Ng, A. Y. and Jordan, M. I. (2003) ‘Latent dirichlet allocation’, *Journal of machine*

- Learning research*, 3(Jan), pp. 993–1022.
- Bollack, L. (1903) *La langue française en l'an 2003...* Bureau de La Revue.
- Deerwester, S. *et al.* (1990) 'Indexing by latent semantic analysis', *Journal of the American society for information science*. Wiley Online Library, 41(6), pp. 391–407.
- Dictionary, O. E. (1989) 'Oxford english dictionary', *Simpson, JA & Weiner, ESC*.
- Dubossarsky, H. *et al.* (2015) 'A bottom up approach to category mapping and meaning change.', in *NetWordS*, pp. 66–70.
- Hamilton, W. L., Leskovec, J. and Jurafsky, D. (2016a) 'Cultural shift or linguistic drift? comparing two computational measures of semantic change', in *Proceedings of the Conference on Empirical Methods in Natural Language Processing. Conference on Empirical Methods in Natural Language Processing*, p. 2116.
- Hamilton, W. L., Leskovec, J. and Jurafsky, D. (2016b) 'Diachronic word embeddings reveal statistical laws of semantic change', in *Proceedings of the 54th Annual Meeting of the Association for Computational Linguistics (Volume 1: Long Papers)*, pp. 1489–1501.
- Hochreiter, S. and Schmidhuber, J. (1997) 'Long short-term memory', *Neural computation*. MIT Press, 9(8), pp. 1735–1780.
- Iacobacci, I., Pilehvar, M. T. and Navigli, R. (2015) 'Sensembded: Learning sense embeddings for word and relational similarity', in *Proceedings of the 53rd Annual Meeting of the Association for Computational Linguistics and the 7th International Joint Conference on Natural Language Processing (Volume 1: Long Papers)*, pp. 95–105.
- Kim, Y. *et al.* (2014) 'Temporal analysis of language through neural language models', in *Proceedings of the ACL 2014 Workshop on Language Technologies and Computational Social Science*, pp. 61–65.
- Kroch, A. S. (1989) 'Reflexes of grammar in patterns of language change', *Language variation and change*. Cambridge University Press, 1(3), pp. 199–244.
- Kutuzov, A., Velldal, E. and Øvrelid, L. (2017) 'Temporal dynamics of semantic relations in word embeddings: an application to predicting armed conflict participants', in *Proceedings of the 2017 Conference on Empirical Methods in Natural Language Processing*, pp. 1824–1829. 2017.
- Lafferty, J., McCallum, A. and Pereira, F. C. N. (2001) 'Conditional random fields: Probabilistic models for segmenting and labeling sequence data'.
- Lin, Y. *et al.* (2012) 'Syntactic annotations for the google books ngram corpus', in *Proceedings of the ACL 2012 system demonstrations*, pp. 169–174.
- Medsker, L. R. and Jain, L. C. (2001) 'Recurrent neural networks', *Design and Applications*. Citeseer, 5.
- Mikolov, T. *et al.* (2013) 'Efficient estimation of word representations in vector space', *arXiv preprint arXiv:1301.3781*.
- Pascanu, R., Mikolov, T. and Bengio, Y. (2013) 'On the difficulty of training recurrent neural networks', in *International Conference on Machine Learning*, pp. 1310–1318.
- Pennington, J., Socher, R. and Manning, C. (2014) 'Glove: Global vectors for word representation', in *Proceedings of the 2014 conference on empirical methods in natural language processing (EMNLP)*, pp. 1532–1543.
- Rosin, G. D., Radinsky, K. and Adar, E. (2017) 'Learning Word Relatedness over Time', in *Proceedings of the 2017 Conference on Empirical Methods in Natural Language Processing*, pp. 1168–1178.
- Steels, L. (2011) 'Modeling the cultural evolution of language', *Physics of Life Reviews*. Elsevier, 8(4), pp. 339–356.
- Szymanski, T. (2017) 'Temporal Word Analogies: Identifying Lexical Replacement with Diachronic Word Embeddings', in *Proceedings of the 55th Annual Meeting of the Association for Computational Linguistics (Volume 2: Short Papers)*, pp. 448–453.
- Traugott, E. C. and Dasher, R. B. (2001) *Regularity in semantic change*. Cambridge University Press.
- Turney, P. D. and Pantel, P. (2010) 'From frequency to meaning: Vector space models of semantics', *Journal of artificial intelligence research*, 37, pp. 141–188.